

Plum Creek Conservation District

Directors:

JAMES A. HOLT, JR., President, *Kyle*
PETER REINECKE, Vice President, *Luling*
LUCY KNIGHT, Secretary-Treasurer, *Lockhart*
VACANT, *Luling*
FRED ROTHERT, *Kyle*
TOM OWEN, *Lockhart*

Staff:

DANIEL MEYER
Executive Manager
KAREN BASSETT
Secretary
MATT SHAW, *Staff Member*
ALAN BURKLUND, *Staff Member*



REQUEST FOR QUOTATIONS (RFQ)

No. PCCD-2020-RFQ2

May 29, 2020

FENCE CONSTRUCTION PROJECT

of

Plum Creek Watershed Floodwater Retarding Structure
Site 7

Hays County, Texas

Contracting Local Organization

Plum Creek Conservation District

Lockhart, Texas



Table of Contents
RFQ No. PCCD-2020-RFQ2

	<u>PAGE NO.</u>
PART I – General Provisions	
Subpart A Notice to Bidders	3
Subpart B Instructions to Bidders	4-5
Subpart C RFQ / BID FORMS (Exhibits A - C)	6-8
Subpart D Sample Contract Agreement	9-10
PART II – General Conditions	11-14
PART III – Supplemental Conditions	15-20
PART IV – Prevailing Wage Rates Determination	21
PART V – Specifications & Maps	22+



PART I – GENERAL PROVISIONS

SUBPART A

NOTICE TO BIDDERS:

Quotations for furnishing all labor, material and equipment and performing all work required for fence construction on Plum Creek Watershed, Floodwater-Retarding Structure, Site 7 will be received until **4:00 p.m. local time, Monday, June 15, 2020**, at Plum Creek Conservation District (PCCD) office, 1101 West San Antonio Street, Lockhart, TX 78644, or may be mailed to this address. Quotations will be reviewed and considered by the PCCD Board of Directors.

Bids must be addressed to the attention of Daniel Meyer, PCCD Executive Manager, and mailed (or hand carried) to the above address in a sealed envelope (placed inside the mailing envelope, if any) labeled as follows:

- (1) RFQ No. PCCD-2020-RFQ2
- (2) Due Date / Time: June 15, 2020 – 4:00 P.M.
- (3) Name and Address of Bidder

Please contact Daniel Meyer, PCCD Executive Manager (phone 512-398-2383) to make an appointment for an authorized person to accompany you to the project site. No unescorted visits to the site are allowed. Interested parties are HIGHLY ENCOURAGED to view the site.

ESTIMATED PRICE RANGE : Between \$30,000 and \$60,000

A contract over \$25,000 will require Contractor to submit a payment bond within 5 (five) workdays after receipt of Notice of Award per PART III, Supplemental Conditions, Article 7. All contracts require Contractor to submit liability and workmen's compensation insurance certificates as outlined in PART III, Supplemental Conditions, Articles 1-3 within the same timeframe.

Any quotation over \$50,000 will require a Bid Guarantee as outlined in Part I, Subpart B, Instructions 5 and 6.

Plum Creek Conservation District ("the District") is a political subdivision of the State of Texas created by special legislative act. Because it is a political subdivision of the State of Texas, certain laws related to contracts are applicable under State Law to entities such as Plum Creek Conservation District and the District is obligated to comply with those laws.

Plum Creek Conservation District reserves the right to reject any and all bids. Telegraphic, electronic, or facsimile (Fax) quotations, modifications, or withdrawals are not authorized. Bids providing less than 60 (sixty) calendar days for acceptance will not be considered and will be rejected.



PART I – GENERAL PROVISIONS

SUBPART B

INSTRUCTIONS TO BIDDERS:

1. **Conditions Affecting the Work:** Interested parties should visit the site and take such other steps as may be reasonably necessary to ascertain the nature and location of the work, and the general and local conditions which can affect the work or the cost thereof. Failure to do so will not relieve quoters from responsibility for estimating properly the difficulty or cost of successfully performing the work. The Contracting Local Organization will assume no responsibility for any understanding or representations concerning conditions made by any of its officers or agents prior to execution of the contract, unless included in the Request for Quotations (RFQ), the specifications, or related documents.

NO digging or taking of core samples will be allowed. Persons visiting the site are asked to take due care to ensure the existing site conditions are not disturbed.

Appointment Required to Visit the Project Sites: Please contact Daniel Meyer, PCCD Executive Manager (phone 512-398-2383) to make an appointment for an authorized person to accompany you to the project site. No unescorted visits to the site are allowed.

2. **Required Bid Information:** Forms which must be included in a bid are:

Exhibit A: Price Quotation (1 page)

Exhibit B: References (1 page)

Exhibit C: Bidder Certifications (1 page)

Bid Guarantee: Only for Bid **Exceeding \$50,000** (see Instructions 5&6 below).

3. **Preparation of Bid:** The bidder must submit his/her offer on the forms furnished in this RFQ, and the quote must be manually signed by a person or persons with authority to legally bind the individual, firm or corporation. If erasures or other changes appear on the forms, each erasure or change must be initialed by the person signing the bid. Facsimile (Fax), electronic, and telegraphic quotations, modifications, or withdrawals **will not** be considered.

Estimated Price Range: Between \$30,000 and \$60,000

Exemption from State, County, and Municipal Sales and Use Taxes. See Part II – General Conditions, Article 11 (Federal, State, and Local Taxes), paragraph (b). **Bidders are entitled to EXCLUDE exempt taxes in their Price Quotation.** Bidder is solely responsible to determine what tangible personal property and taxable services are eligible for exemption from these taxes.

4. **Explanation to Bidders / Inquiries:** Any explanation desired by a bidder regarding the meaning or interpretation of the RFQ, specifications, etc., must be requested in writing by noon on June 9, 2020. Written requests shall be mailed, hand delivered, or sent via facsimile machine or email (telegraphic inquiries will not be accepted) to:

a. Daniel Meyer, Executive Manager, Plum Creek Conservation District, 1101 West San Antonio Street, Lockhart, TX 78644

FAX #: 512-398-7776

EMAIL: daniel.meyer@pccd.org

5. **Bid Guarantee (only for bid exceeding \$50,000):** As a good faith deposit to ensure execution of a contract, each quotation exceeding \$50,000 must be accompanied by a bid guarantee in the form of a certified or cashier's check (on a responsible bank in Texas) or bid bond, in the amount of not less than two percent (2%) of the total bid. Bid guarantee is to be made payable to: PLUM CREEK



CONSERVATION DISTRICT. Bid guarantees, other than bid bonds, will be returned (a) to all bidders (except the three most qualified) within 3 days of the date quotes are due, and (b) to the three most qualified bidders upon execution by the most qualified bidder of such further contractual documents and bonds as may be required by the bid as accepted. When a bid guarantee is required, failure to furnish a bid guarantee in the proper form and amount, may be cause for rejection of the bid.

Should the bidder to whom the contract is awarded fail or refuse to enter into a proper contract with the PCCD, or fail or refuse to furnish the payment bond (for contract exceeding \$25,000) required by PART III, Article 7, or fail or refuse to provide additional Post-Award Information required by PART III, Article 4, within the time specified, the bidder forfeits the bid guarantee, and/or the CLO may pursue any other action allowed by law.

6. **Bid Bond Requirements (only for bid exceeding \$50,000):** Bond must be executed by a corporate surety authorized and admitted to write surety bonds in the State of Texas. All bonds signed by an agent must be accompanied by a certified copy of such agent's authority to act. The original of bid bond shall be submitted with the bid.
7. **Submission of Post-award Information:** Within five (5) workdays after receipt of Notice of Award, Contractor will be required to submit post-award information as specified in PART III, Supplemental Conditions, Article 4.
8. **Award of Contract:** Award of contract will be made to that responsible bidder whose bid, conforming to the Request for Quotations (RFQ), is most advantageous to the Contracting Local Organization, price and other factors considered. The Contracting Local Organization may, when in its interest, **reject any or all bids or waive informalities or minor irregularities in bids received**. Only one contract will be awarded and the award will be based on the total bid.

A response to an RFQ is an offer to contract with the Contracting Local Organization based upon the terms, conditions and specifications contained in the RFQ. **Bids do not become contracts until a signed Notice of Award (NOA) is issued by the Contracting Local Organization.**

Award of Contract to Nonresident Bidder. In accordance with Texas Government Code 2252.002, PCCD may not award a contract to a nonresident bidder unless the nonresident underbids the lowest bid submitted by a responsible resident bidder by an amount that is not less than the amount by which a resident bidder would be required to underbid the nonresident bidder to obtain a comparable contract in the state in which the nonresident's principal place of business is located.
9. **Officials Not to Benefit:** Any contract to be awarded as a result of this solicitation will not be awarded to any official of the Texas State Soil and Water Conservation Board, Plum Creek Conservation District, or Hays County Soil and Water Conservation District (SWCD), (all in the State of Texas), or to any firm in which any official or any member of such official's immediate family of these entities has direct or indirect interest in the pecuniary profits or contracts of such firms.
10. **Execution of Contract and Submission of Post-award Information:** The contract will include items outlined in PART I, Subpart D, Sample Contract Agreement, Article V. Within five (5) workdays after receipt of Notice of Award of the contract, the successful bidder shall execute the Contract Agreement and furnish the Contracting Local Organization with required post-award information as outlined in PART III, Supplemental Conditions, Article 4.
11. **Approval of Contract:** The contract will be approved and signed by the Plum Creek Conservation District President. The contract will not be binding upon the Contracting Local Organization until it has been executed by Plum Creek Conservation District and delivered to the Contractor.



PART I – GENERAL PROVISIONS

SUBPART C

BID FORMS:

EXHIBIT A: Price Quotation / Bid

RFQ No. PCCD-2020-RFQ2

The undersigned, in compliance with Request for Quotations (RFQ) No. PCCD-2020-RFQ2 for Plum Creek Watershed, Floodwater Retarding Structure (FRS) Site 7 Fence Construction project, in Hays County, Texas, having examined the specifications and RFQ documents, the site of the proposed work, and being familiar with all the conditions surrounding performance of the proposed project; agrees to furnish all labor, material and equipment and perform all work required in accordance with the specifications and contract documents for the prices below, if this offer is accepted by the Contracting Local Organization within _____ calendar days after the date bids are due. *[Note: Failure to insert a number means the bidder accepts the minimum sixty (60) calendar days as required in Notice to Bidders.]*

NOTE: Bidders are entitled to EXCLUDE exempt taxes in their bid prices (see PART II, General Conditions, Article 11).

<p>TOTAL BID PRICE Fence Construction Project (Site 7):</p> <p>In Figures: \$ _____</p> <p>In Words: _____ Dollars</p> <p>and _____ Cents</p> <p>NOTE: AMOUNTS SHALL BE SHOWN IN BOTH WORDS AND FIGURES. IN CASE OF DISCREPANCY, THE AMOUNT SHOWN IN WORDS WILL GOVERN.</p>
--

Bidder's Name/Title (type or print): _____

Bidder's Signature: _____

Company Name: _____

Date: _____



EXHIBIT B: REFERENCES

RFQ No. PCCD-2020-RFQ2

Quoter in accordance with PART I, Subpart B, Instructions to Bidders, Section 2, shall list below up to three (3) recent projects upon which he/she has performed work similar to that specified herein. All lines for each reference shall be filled in completely with up-to-date information. Any omissions to this form, discrepancies in reference, or unverifiable information may be grounds for disqualification of the bidder.

1. Project Name: _____
 Owner: _____ Total Contract Cost: \$ _____
 Location: _____ Completion Date: _____
 Description of Work: _____

 Contact: _____ Phone Number: (____) _____

2. Project Name: _____
 Owner: _____ Total Contract Cost: \$ _____
 Location: _____ Completion Date: _____
 Description of Work: _____

 Contact: _____ Phone Number: (____) _____

3. Project Name: _____
 Owner: _____ Total Contract Cost: \$ _____
 Location: _____ Completion Date: _____
 Description of Work: _____

 Contact: _____ Phone Number: (____) _____



EXHIBIT C: BIDDER CERTIFICATIONS

RFQ No. PCCD-2020-RFQ2

By submission of this price quotation, bidder certifies to all Sections in this Exhibit C.

Bidder should **circle appropriate answers** in Sections **A, B, and C** and fill in blank in Section **E**.

SECTION A: Texas Franchise Tax Certification

Bidder [**IS / IS NOT**] currently delinquent in the payment of any franchise tax owed to the State of Texas, or is exempt from, or not subject to, such tax.

SECTION B: Texas Resident/Nonresident Bidder Certification

Bidder [**IS / IS NOT**] a Texas resident bidder as defined below.

DEFINITIONS: Per State of Texas House Bill 620.

“Nonresident bidder” means a bidder whose principal place of business is not in this state, but excludes a contractor whose ultimate parent company or majority owner has its principal place of business in this state.

“Texas resident bidder” means a bidder whose principal place of business is in this state, and includes a contractor whose ultimate parent company or majority owner has its principal place of business in this state.

SECTION C: Authority to Transact Business in Texas Certificate

Complete ONLY if you are a Texas nonresident bidder.

- (1) Texas nonresident bidder [**IS / IS NOT**] a corporation, limited partnership, or limited liability company. *If answer is “IS NOT”, do not complete C(2) and C(3) below.*
- (2) Bidder [**HAS / HAS NOT**] obtained a Certificate of Authority through the Texas Secretary of State to transact business in Texas. **Attach a copy of Certificate to bid if available.**
- (3) If response to C(2) is “HAS NOT”, bidder agrees to present a current Certificate of Authority to the Contracting Local Organization by date post-award information is due: [**YES / NO**]

SECTION D: Officials Not to Benefit: Bidder certifies that its firm is not an official of the Plum Creek Conservation District, the Texas State Soil and Water Conservation Board, or Hays County Soil and Water Conservation District (SWCD), (all in the State of Texas), or a firm in which any official or any member of such official’s immediate family of these entities has direct or indirect interest in the pecuniary profits or contracts of its firm.

SECTION E: Bonding (bid exceeding \$25,000): Per Texas Administrative Code Rule 293.63(5), bidder must submit, along with the quotation, the name of the person, firm, or corporation that will execute payment bond as required in PART III, Article 7: **List information below:**



PART I – GENERAL PROVISIONS

SUBPART D

Sample Contract Agreement:

CONTRACT AGREEMENT (sample)

THIS AGREEMENT, made the _____ day of _____, 2020, by and between the Plum Creek Conservation District, Lockhart, Texas (hereinafter called Owner) and _____ (hereinafter called Contractor).

WITNESSETH:

THAT WHEREAS: in accordance with law, Owner had contract documents prepared and a Request for Quotations published (RFQ No. PCCD-2020-RFQ2), for and in connection with the Fence Construction Project of Plum Creek Watershed, Floodwater Retarding Structure Site 7, Hays County, Texas; and

WHEREAS, Contractor, in response to the Request for Quotations, has submitted to Owner, in the manner and at the time specified, a price quotation in accordance with Instructions to Bidders; and

WHEREAS, Owner, in the manner prescribed by law, has opened, examined, and canvassed the quotations submitted, and has determined Contractor to be the lowest responsible bidder for the work and duly awarded to Contractor a contract therefor, for the sum or sums named in Contractor’s quotation.

NOW, THEREFORE, in consideration of the compensation to be paid to Contractor and of the mutual agreements herein contained, the parties have agreed and hereby agree, Owner for itself and its successors and assigns, and its, his/her, or their executors and administrators, as follows:

ARTICLE I. Contractor shall perform all work, including the assumption of all obligations, duties and responsibilities necessary to the successful completion of the contract and the furnishing of all materials and equipment required to be incorporated in and form a permanent part of the work; tools, equipment, supplies, transportation, facilities, labor, superintendence and services required to perform the work; and bonds, insurance and submittals; all as indicated or specified in the contract documents to be performed or furnished by Contractor for the work included in and covered by Owner’s official award of this contract to Contractor, such award being based on the acceptance by Owner of Contractor’s written quotation.

ARTICLE II. Owner shall pay to Contractor for performance of the work embraced in this contract, and Contractor shall accept as full compensation therefor, the sum (subject to adjustment as provided in the contract documents) of _____ Dollars (\$ _____) for all work covered by and included in the contract award and designated in the foregoing Article I; payment thereof to be made in current funds in the manner provided in the contract documents.

ARTICLE III. The Contractor shall complete all work within thirty-two(32) working days from the date Contractor receives written Notice to Proceed.

ARTICLE IV. Contractor has carefully examined, reviewed, and accepted this Contract Agreement and there are no discrepancies, errors, omissions, ambiguities or conflicts in this Contract that are material to Contractor’s provision, performance or completion of the work, the contract price or contract performance time that have not been clarified in writing by the PCCD to the satisfaction of the Contractor. Contractor shall hereafter have no claim for payment or compensation in excess of the Contract price.



ARTICLE V. The contract documents that comprise the Contract between Owner and Contractor, attached hereto and made a part hereof, consist of the following:

- (1) This Contract Agreement.
- (2) Contractor's Bid/Price Quotation: PART I, Subpart C, Exhibits A - C.
- (3) Request for Quotations (RFQ) Amendment Numbers _____.
- (4) Post-bid information and supplementary information submitted by Contractor prior to execution of this Contract Agreement.
- (5) Notice of Award.
- (6) PART II – General Conditions.
- (7) PART III – Supplemental Conditions.
- (8) PART IV – Prevailing Wage Rates Determination.
- (9) PART V – Specifications and Maps.
- (10) Notice to Proceed.
- (11) Any modifications (change orders) duly delivered or supplemental agreements duly entered into after execution of this Contract Agreement.
- (12) Notices of Final Completion and Acceptance.

IN WITNESS WHEREOF, the parties hereto have executed this Contract Agreement the day and year first above written.

OWNER

CONTRACTOR

PLUM CREEK CONSERVATION DISTRICT

By _____

By _____

JAMES A. HOLT, JR.
President, Plum Creek Conservation District

Title _____

(CORPORATE SEAL)

Attest _____

Attest _____

Address for giving notices:
Plum Creek Conservation District
1101 West San Antonio Street
Lockhart, TX 78644

Address for giving notices

This action authorized at an official meeting
of the Plum Creek Conservation District on
_____ [add date], Lockhart, Texas

License No. _____

Agent for service of process:

DANIEL MEYER
PCCD Executive Manager

(If Contractor is a corporation, attach
evidence of authority to sign.)



PART II - GENERAL CONDITIONS

ARTICLE 1 – DEFINITIONS

Terms used or referred to herein and elsewhere in the contract documents are defined as follows:

(a) Contracting Local Organization (CLO): The organization or agency awarding the contract. (CLO) is the Plum Creek Conservation District, Lockhart, Texas. Also referred to as District, Government, and Owner.

(b) Contracting Officer (CO): The person who is designated and authorized to enter into and administer this contract on behalf of the Contracting Local Organization or his/her duly appointed successor or alternate. No other person has authority to act for the Contracting Officer as stated in these General Conditions or elsewhere in the contract documents unless such person has been delegated authority by the Contracting Officer in writing. Also referred to as Owner's Representative. Contracting Officer for this project is Daniel Meyer; Alternate Contracting Officer is Alan Burklund.

ARTICLE 2 – CHANGES

(a) It may be necessary for the District to consider changes to the specifications of the project that may arise due to unforeseen circumstances. Prior to any decisions being made, the CLO will discuss with the Contactor the changes that are being considered. If any change under this article causes an increase or decrease in the Contractor's cost of, or the time required for, the performance of any part of the work under this contract, whether or not changed by any order, an equitable adjustment shall be made and the contract modified in writing accordingly.

ARTICLE 3 – PAYMENTS

(a) Progress payments will be made monthly in accordance with Texas Water Code 49.276 and Texas Government Code 2251. Progress payments will be based on the amount of work performed during that period and are subject to 10% retainage on the first 50 percent of the work completed.

(b) Final payment shall be conditioned upon the satisfactory completion of the work as determined after final inspection and acceptance by the PCCD. Any retainage will be released to Contractor with the final payment.

(c) The acceptance by Contractor of final payment shall operate as a full and complete release of the PCCD of and from any and all lawsuits, claims, demands, damages, liabilities, losses, and expenses of, by, or to Contractor for anything done, furnished for, arising out of, relating to, or in connection with the work or for or on account of any act or neglect of the PCCD arising out of, relating to, or in connection with the work.

ARTICLE 4 – WORKWEEK

The maximum allowable workweek is Monday through Saturday, up to 12 hours per day. Work is permitted during daylight hours only. No work is permitted on Sundays or on major holidays (i.e., Memorial Day, Independence Day, and Labor Day).

ARTICLE 5 – PERMITS AND RESPONSIBILITIES

The Contractor shall, without additional expense to the Contracting Local Organization, be responsible for obtaining any necessary licenses and permits, and for complying with any applicable Federal, State, and municipal laws, codes, and regulations, in connection with the prosecution of the work.

ARTICLE 6 – OTHER CONTRACTS

The Contracting Local Organization may undertake fertilizing/pesticide application during this contract period. The Contractor shall fully cooperate with such other contractors and Contracting Local Organization employees and carefully fit his/her own work to such additional work as may be directed by the Contracting Officer. The Contractor shall not commit or permit any act which will interfere with the performance of work by any other contractor or by Contracting Local Organization employees.



ARTICLE 7 – SUBCONTRACTORS

(a) Work shall not be subcontracted in whole or in part without the prior written approval of the Contracting Officer. The request shall be in writing with the name and qualifications of the proposed subcontractor and a description of the work to be done.

(b) If at any time the Contracting Officer determines that any subcontractor is incompetent or undesirable, he/she shall notify the Contractor accordingly and the Contractor shall take immediate steps for cancellation of the subcontract.

(c) Subcontracting by subcontractors shall be subject to the above requirements.

(d) Nothing contained in this contract shall create any contractual relationship between any subcontractor and the Contracting Local Organization.

(e) Any subcontract awarded under this contract will not be awarded to any official of the Plum Creek Conservation District, Texas State Soil and Water Conservation Board, or Hays County Soil and Water Conservation District, (all in the State of Texas), or to any firm in which any official or any member of such official's immediate family of these entities has direct or indirect interest in the pecuniary profits or contracts of such firms.

ARTICLE 8 – CLEANUP WORK

(a) During performance of the work the Contractor shall keep the work site, areas adjacent to the work site and access roads in an orderly condition, free and clear from debris and discarded materials. Care shall be taken to prevent spillage when hauling is being done. Any spillage or debris resulting from the Contractor's operations shall be immediately removed.

(b) Upon completion of the work the Contractor shall remove from the work site, areas adjacent to the work site and access roads: all plant, buildings, debris, unused materials, concrete forms and other like material belonging to Contractor or used under his/her direction during the construction. Contractor shall grade all access roads, other than public, removing wheel tracks and smoothing up such roads.

ARTICLE 9 – ASSIGNMENT

The Contractor shall not assign in whole or in part this contract without the prior written consent of the Contracting Local Organization. The Contractor shall not assign any moneys due or to become due to him/her under this contract without the prior written consent of the Contracting Local Organization. No claim as a third-party beneficiary under this Contract by any person, firm, or corporation other than Contractor shall be made or be valid against the PCCD, and the PCCD shall not be liable for or be held to pay any money to any such person.

ARTICLE 10 – NONCOMPLIANCE WITH CONTRACT REQUIREMENTS

(a) The Contracting Officer may order suspension of the work in whole or in part for such time as he/she deems necessary because of the failure of the Contractor to comply with any of the requirements of this contract, and the contract completion date shall not be extended on account of any such suspension of the work.

(b) When the Contracting Officer orders any suspension of the work under (a) of this article, the Contractor shall not be entitled to any costs or damages resulting from such suspension.

(c) The rights and remedies of the Contracting Local Organization provided in this article are in addition to any other rights and remedies provided by law or under this contract.

ARTICLE 11 – FEDERAL, STATE, AND LOCAL TAXES

(a) Except as otherwise provided, contract unit prices shall include all applicable Federal, State, and local taxes.

(b) Texas State, County, and Municipal Sales and Use Tax. (1) The Contracting Local Organization is an exempt entity per §151.309(5) of the Limited Sales, Excise, and Use Tax Act (Texas Tax Code Chapter 151 – Limited Sales, Excise, and Use Tax) and will issue the Contractor an affidavit as proof of this exemption. This contract is a "lump-sum contract" as defined by Texas Administrative Code, Title 34, Part 1, Chapter 3, Subchapter O – State Sales and Use Tax, Rule §3.291 (Contractors).

(2) When purchased by the Contractor for use in performance of this contract, certain tangible personal property and taxable services are exempt from State Sales and Use Tax under Texas Tax Code §151.311, and in most cases are also exempt from County and Municipal Sales and Use Tax. Contractor



is subject to tax responsibilities in Texas Administrative Code Rule §3.291, section (c), and is responsible to issue a properly completed exemption certificate to a supplier in accordance with section (c)(5).

(3) Contractor is solely responsible to be adequately familiar with and comply with all requirements of Texas Tax Code, Texas Administrative Codes, and any other State/local regulations when claiming tax exemption for purchase of items for use in the performance of this contract.

(4) "Contractor" as used in this paragraph (b) includes subcontractors as defined in Texas Administrative Code Rule §3.291, section (a)(3).

(c) Upon execution of the Contract Agreement, PCCD will provide Contractor a tax exempt certificate for this project.

ARTICLE 12 – INSPECTION AND ACCEPTANCE / WORKMANSHIP

(a) All work under this contract shall be performed in a skillful and workmanlike manner. The Contracting Officer may, in writing, require the Contractor to remove from the work any employee, including subcontractors, the Contracting Officer deems incompetent, careless, or otherwise objectionable.

(b) The Contractor shall, without charge, correct any workmanship found by the Contracting Local Organization not to conform to the contract requirements, unless in the public interest the Contracting Local Organization consents to accept such material or workmanship with an appropriate adjustment in contract price.

(c) Contractor shall be responsible for all materials delivered and work performed until completion and acceptance of the entire construction work, except for any completed unit of construction thereof which theretofore may have been accepted.

(d) Unless otherwise provided in this contract, acceptance by the Contracting Local Organization shall be made as promptly as practicable after completion and inspection of all work required by this contract, or that portion of the work that the Contracting Officer determines can be accepted separately. Acceptance shall be final and conclusive except as regards latent defects, fraud, or such gross mistakes as may amount to fraud, or as regards the Contracting Local Organization's rights under any warranty or guarantee.

ARTICLE 13 – TERMINATION

(a) This Contract may be terminated at any time by PCCD for any cause. Upon receipt of such notice by PCCD, the Contractor shall immediately discontinue all work and actions on behalf of PCCD.

(b) As soon as practicable after receipt of notice of termination, the Contractor shall submit a statement showing in detail the costs of work performed through the date the notice of termination is received by Contractor.

ARTICLE 14 – TERMINATION FOR DEFAULT, DAMAGES FOR DELAY, TIME EXTENSIONS

(a) If the Contractor refuses or fails to prosecute the work, or any separable part thereof, with such diligence as will insure its completion within the time specified in this contract, or any extension thereof, or fails to complete said work within such time, the Contracting Local Organization may, by written notice to the Contractor, terminate Contractor's right to proceed with the work or such part of the work as to which there has been delay. In such event the Contracting Local Organization may take over the work and prosecute the same to completion, by contract or otherwise, and may take possession of and utilize in completing the work such materials, appliances, and plant as may be on the site of the work and necessary therefor. Whether or not the Contractor's right to proceed with the work is terminated, Contractor and his/her sureties shall be liable for any damage to the Contracting Local Organization resulting from his/her refusal or failure to complete the work within the specified time.

(b) If the Contracting Local Organization so terminates the Contractor's right to proceed, the resulting damage will consist of such actual damages until such reasonable time as may be required for final completion of the work together with any increased costs occasioned the Contracting Local Organization in completing the work.

(c) If the Contracting Local Organization does not so terminate the Contractor's right to proceed, the resulting damage will consist of such actual damages until the work is completed or accepted.

(d) The Contractor's right to proceed shall not be so terminated nor the Contractor charged with resulting damage if:



(1) The delay in the completion of the work arises from unforeseeable causes beyond the control and without the fault or negligence of the Contractor, including but not restricted to, acts of God, acts of the public enemy, acts of the Contracting Local Organization in its contractual capacity, acts of another contractor in the performance of a contract with the Contracting Local Organization, fires, floods, epidemics, quarantine restrictions, strikes, freight embargoes, unusually severe weather, or delays of subcontractors or suppliers arising from unforeseeable causes beyond the control and without the fault or negligence of both the Contractor and such subcontractors or suppliers; and

(2) The Contractor, within 10 days from the beginning of any such delay (unless the Contracting Officer grants a further period of time before the date of final payment under the contract), notifies the Contracting Officer in writing of the causes of delay.

The Contracting Officer shall ascertain the facts and the extent of the delay and extend the time for completing the work when, in his/her judgment, such an extension is justified.

(e) The rights and remedies of the Contracting Local Organization provided in this article are in addition to any other rights and remedies provided by law or under this contract.

(f) As used in paragraph (d)(1) of this article, the term "subcontractors and suppliers" means subcontractors and suppliers at any tier.



PART III - SUPPLEMENTAL CONDITIONS

ARTICLE 1 – TYPES AND LIMITS OF INSURANCE

Satisfactory certificates of insurance shall be filed with Contracting Local Organization prior to commencement of any work on this contract. Insurance requirements stated below do not establish limits of the Contractor’s liability.

(a) Workmen's Compensation and Employer's Liability Insurance

(1) Contractor shall provide workmen’s compensation and employee’s liability insurance at own expense. This insurance shall protect Contractor against all claims under applicable state workmen's compensation laws. Contractor shall also be protected against claims for injury, disease, or death of employees which, for any reason, may not fall within the provisions of a workmen's compensation law.

(2) The liability limits shall be not less than:

Workmen's Compensation	Statutory
Employer's Liability	\$500,000

(b) Comprehensive Automobile Liability Insurance

(1) Contractor shall provide comprehensive automobile liability insurance at own expense. This insurance shall be written in comprehensive form and shall protect Contractor against all claims for injuries to members of the public and damage to property of others arising from the use of motor vehicles, and shall cover operation on or off the site of all motor vehicles licensed for highway use, whether they are owned, non-owned, or hired.

(2) The liability limits shall be not less than:

Bodily injury	\$250,000 each person \$500,000 each occurrence
Property damage	\$250,000 each occurrence

(c) Comprehensive General Liability Insurance

(1) Contractor shall provide comprehensive general liability insurance at own expense. This insurance shall be written in comprehensive form and shall protect Contractor against all claims arising from injuries to persons other than his/her employees or damage to property of Contracting Local Organization or others arising out of any act or omission of Contractor or his/her agents, employees, or subcontractors. The policy shall also include protection against claims insured by usual personal injury liability coverage, such as a "protective liability" endorsement to insure the contractual liability assumed by Contractor.

(2) To the extent that Contractor's work, or work under his/her direction, may require blasting, explosive conditions, or underground operations, the comprehensive general liability coverage shall contain no exclusion relative to blasting, explosion, collapse of building, or damage to underground property.

(3) The liability limits shall be not less than:

Bodily injury	\$500,000 each occurrence
Property damage	\$250,000 each occurrence
Aggregate	\$1 million

(d) Umbrella Liability Policy. If aggregate of Comprehensive General Liability Insurance in (c)(3) above does not equal or exceed \$1 million, the Contractor shall provide umbrella liability policy at its own expense. This insurance shall protect Contractor against all claims in excess of the limits provided under the workmen's compensation and employer's liability, comprehensive automobile liability, and general liability policies. The liability limits of the umbrella liability policy shall not be less than \$1,000,000.



ARTICLE 2 – POLICY CANCELLATION

Each policy shall contain a provision that the coverage afforded will not be canceled or materially changed until at least 30 days prior written notice has been given to the Contracting Local Organization or Contracting Officer.

ARTICLE 3 – WORKERS’ COMPENSATION INSURANCE COVERAGE

Contractor shall provide worker’s compensation insurance coverage as specified below at own expense.

(a) Definitions. (1) Certificate of coverage (“certificate”)—A copy of a certificate of insurance, a certificate of authority to self-insure issued by the TX Department of Insurance, Division of Workers’ Compensation, or a coverage agreement (DWC Form-81, DWC Form-82, DWC Form-83, or DWC Form-84), showing statutory workers’ compensation insurance coverage for the person’s or entity’s employees providing services on a project, for the duration of the project.

(2) Duration of the project—Includes the time from the beginning of the work on the project until the Contractor’s/person’s work on the project has been completed and accepted by the Contracting Local Organization.

(3) Persons providing services on the project (“subcontractor” in §406.096, Texas Labor Code) includes all persons or entities performing all or part of the services the Contractor has undertaken to perform on the project, regardless of whether that person contracted directly with the Contractor and regardless of whether that person has employees. This includes, without limitation, independent contractors, subcontractors, leasing companies, motor carriers, owner-operators, employees of any such entity, or employees of any entity which furnishes persons to provide services on the project. “Services” include, without limitation, providing, hauling, or delivering equipment or materials, or providing labor, transportation, or other service related to a project. “Services” does not include activities unrelated to the project, such as food/beverage vendors, office supply deliveries, and delivery of portable toilets.

(b) The Contractor shall provide coverage, based on proper reporting of classification codes and payroll amounts and filing of any coverage agreements, which meets the statutory requirements of Texas Labor Code, Section 401.011 (44) for all employees of the Contractor providing services on the project, for the duration of the project.

(c) The Contractor must provide a certificate of coverage to the Contracting Local Organization prior to being awarded the contract.

(d) If the coverage period shown on the Contractor’s current certificate of coverage ends during the duration of the project, the Contractor must, prior to the end of the coverage period, file a new certificate of coverage with the Contracting Local Organization showing that coverage has been extended.

(e) The Contractor shall obtain from each person providing services on a project, and provide to the Contracting Local Organization:

(1) A certificate of coverage, prior to that person beginning work on the project, so the Contracting Local Organization will have on file certificates of coverage showing coverage for all persons providing services on the project, and

(2) No later than seven days after receipt by the Contractor, a new certificate of coverage showing extension of coverage, if the coverage period shown on the current certificate of coverage ends during the duration of the project.

(f) The Contractor shall retain all required certificates of coverage for the duration of the project.

(g) The Contractor shall notify the Contracting Local Organization in writing by certified mail or personal delivery, within 10 days after the Contractor knew or should have known, of any change that materially affects the provision of coverage of any person providing services on the project.

(h) The Contractor shall post on each project site a notice [see paragraph (l) of this Article], in the text, form and manner prescribed by the Texas Department of Insurance, Division of Workers’ Compensation, informing all persons providing services on the project that they are required to be covered, and stating how a person may verify coverage and report lack of coverage.

(i) The Contractor shall contractually require each person with whom it contracts to provide services on a project, to:



(1) Provide coverage, based on proper reporting of classification codes and payroll amounts and filing of any coverage agreements, which meets the statutory requirements of Texas Labor Code, Section 401.011 (44) for all of its employees providing services on the project, for the duration of the project;

(2) Provide to the Contractor, prior to that person beginning work on the project, a certificate of coverage showing that coverage is being provided for all employees of the person providing services on the project, for the duration of the project;

(3) Provide the Contractor, prior to the end of the coverage period, a new certificate of coverage showing extension of coverage, if the coverage period shown on the current certificate of coverage ends during the duration of the project;

(4) Obtain from each other person with whom it contracts, and provide to the Contractor:

(i) a certificate of coverage, prior to the other person beginning work on the project; and

(ii) a new certificate of coverage showing extension of coverage, prior to the end of the coverage period, if the coverage period shown on the current certificate of coverage ends during the duration of the project;

(5) Retain all required certificates of coverage on file for the duration of the project;

(6) Notify the Contracting Local Organization in writing by certified mail or personal delivery, within 10 days after the person knew or should have known, of any change that materially affects the provision of coverage of any person providing services on the project; and

(7) Contractually require each person with whom it contracts, to perform as required by paragraphs (1) - (7), with the certificates of coverage to be provided to the person for whom they are providing services.

(j) By signing this contract or providing or causing to be provided a certificate of coverage, the Contractor is representing to the Contracting Local Organization that all employees of the Contractor who will provide services on the project will be covered by workers' compensation coverage for the duration of the project, that the coverage will be based on proper reporting of classification codes and payroll amounts, and that all coverage agreements will be filed with the appropriate insurance carrier or, in the case of a self-insured, with the TX Department of Insurance, Division of Workers' Compensation. Providing false or misleading information may subject the Contractor to administrative penalties, criminal penalties, civil penalties, or other civil actions.

(k) The Contractor's failure to comply with any of these provisions is a breach of contract by the Contractor which entitles the Contracting Local Organization to declare the contract void if the Contractor does not remedy the breach within ten days after receipt of notice of breach from the Contracting Local Organization.

(l) Posting of Notice: "REQUIRED WORKER'S COMPENSATION COVERAGE"

"The law requires that each person working on this site or providing services related to this construction project must be covered by workers' compensation insurance. This includes persons providing, hauling, or delivering equipment or materials, or providing labor or transportation or other service related to the project, regardless of the identity of their employer or status as an employee.

Call the Division of Workers' Compensation at 1-800-252-7031 or access the division's website at www.tdi.texas.gov/wc/indexwc.html to receive information on the legal requirement for coverage, to verify whether your employer has provided the required coverage, or to report an employer's failure to provide coverage."

ARTICLE 4 – POST-AWARD INFORMATION

Within five (5) workdays after receipt of Notice of Award, Contractor shall submit to the Contracting Officer the following post-award information:

(a) Two (2) fully executed counterparts of the Contract Agreement including all the contract documents.

(b) Payment bond (contract over \$25,000) as specified in Article 7 of these Supplemental Conditions.

(c) Copy of all insurance certificates required in Articles 1, 2, and 3 of these Supplemental Conditions.

(d) List of proposed subcontractors required in PART II, General Conditions, Article 7(a).

Only applicable to bid over \$50,000. Should the bidder to whom the contract is awarded fail or refuse to enter into a proper contract with the CLO, or fail or refuse to comply with these conditions within the



time specified, the bidder forfeits the bid guarantee, and/or the CLO may pursue any other action allowed by law.

ARTICLE 5 – COMMENCEMENT, PROSECUTION, AND COMPLETION OF WORK

(a) It is understood and agreed that time is of the essence, and Contractor agrees to begin actual work of the fence construction project covered by this contract in conformity with the timeline. The completion of the contract shall be within thirty-two (32) working days after the notice to proceed is received by the Contractor. Major Holidays (i.e., Memorial Day, Independence Day, Labor Day) and Sundays do not count towards the 32 days. Additional performance time will be allowed for days that in the Contracting Officer’s opinion are too wet to allow access or satisfactory prosecution of the work.

(b) The Contractor warrants it is ready, willing, able and prepared to begin the work

ARTICLE 6 – WAGES / BENEFITS

6.1 General

Contractor shall pay or cause to be paid, without cost or expense to Contracting Local Organization, all Social Security, Unemployment and Federal Income Withholding Taxes of all such employees, and all such employees shall be paid wages and benefits as required by Federal and/or State law (including but not restricted to unemployment compensation coverage) and per wage rates requirements in Article 6.2 below. In accordance with Texas Labor Code §61.012, Contractor shall post in conspicuous places in the workplace notices indicating the paydays.

6.2 Laborers and Mechanics – Prevailing Wage Rates

(a) This contract requires the Contractor and any of his/her subcontractors at any tier to pay prevailing wage rates as specified in this article and to follow requirements contained in Texas Government Code, Chapter 2258, Prevailing Wage Rates.

(b) A copy of the Prevailing Wage Rates Determination that must be followed is included in PART IV of the contract.

(c) A worker employed or working upon the site of the work shall be paid the full amount of wages and bona fide fringe benefits (or cash equivalents thereof) computed at rates not less than those contained in the Prevailing Wage Rates Determination for regular work and for legal holiday and overtime work, regardless of any contractual relationship which may be alleged to exist between the Contractor and such workers. “Worker” includes laborers or mechanics.

(d) Workers shall be paid not less than the appropriate wage rate and fringe benefits in the wage determination for the classification of work actually performed, without regard to skill. Those performing work in more than one classification may be compensated at the rate specified for each classification for the time actually worked therein; provided that the employer’s payroll records accurately set forth the time spent in each classification in which work is performed.

(e) The wage determination shall be posted at all times by the Contractor and subcontractors at the site of the work in a prominent and accessible place where it can be easily seen by workers.

(f) Whenever the minimum wage rate prescribed in the contract for a class of laborers or mechanics includes a fringe benefit which is not expressed as an hourly rate, the Contractor shall either pay the benefit as stated in the wage determination or shall pay another bona fide fringe benefit or an hourly cash equivalent thereof.

(g) The Contractor or subcontractor shall insert in any subcontracts this Article 6, and also a clause requiring subcontractors to include Article 6 in any lower tier subcontracts. The Prime Contractor shall be responsible for compliance by any subcontractor or lower tier subcontractor with this article.

(h) Payroll records. A Contractor and subcontractor shall keep a record showing: (i) the name and occupation of each worker (includes a laborer or mechanic) employed by the Contractor or subcontractor in the construction of the public work; and (ii) the actual per diem wages paid to each worker. The record shall be open at all reasonable hours to inspection by the officers and agents of the Contracting Local Organization and others.

(i) A Contractor or subcontractor who violates this article shall pay to the Contracting Local Organization a penalty of \$60 for each worker employed for each calendar day or part of the day that the worker is paid less than the wage rates stipulated.



ARTICLE 7 – PAYMENT BONDS (only for contract exceeding \$25,000)

7.1 General

(a) If the contract price exceeds \$25,000, this contract requires a payment bond as outlined in 7.2 below. The bond is due within five (5) workdays after receipt of Notice of Award (see Article 4 of these Supplemental Conditions). The Contracting Local Organization will attach to the Notice of Award the bond form to be used.

(b) The Bond shall be made payable to: Plum Creek Conservation District.

(c) The Bond is subject to requirements stated in this Article and requirements of Texas Government Code, Chapter 2253, Public Work Performance and Payment Bonds, and must be executed by a corporate surety in accordance with Texas Insurance Code, Chapter 3503 (Surety Bonds and Related Instruments), Subchapter A.

7.2 Payment Bonds—Construction (contract exceeding \$25,000)

(a) *Definitions.* As used in this clause-- "Contract price" means the award price of the contract. "Government" means the Contracting Local Organization.

(b) The successful offeror shall be required to furnish a payment bond to the Contracting Officer as follows:

(1) *Payment Bond:*

(i) The penal amount of payment bond shall be 100 percent of the original contract price.

(ii) The Government may secure additional protection by directing the Contractor to increase the penal sum of the existing bond or to obtain an additional bond.

(c) The Contractor shall furnish the executed bond, including any necessary reinsurance agreements, to the Contracting Officer, within the time period specified in 7.1 above.

(d) A bond may be executed only by a corporate surety company that is authorized and admitted to write surety bonds in the State of Texas.

(e) Payment Bond Over \$100,000 only. The surety must (i) hold a certificate of authority from the United States Secretary of the Treasury to qualify as a surety on obligations permitted or required under federal law; or (ii) have obtained reinsurance for any liability in excess of \$1,000,000 from a reinsurer that is an authorized reinsurer in the State of Texas or is a holder of a certificate of authority from the United States Secretary of the Treasury to qualify as a surety or reinsurer on obligations permitted or required under federal law. U.S. Treasury Department Circular 570 is published in the *Federal Register* and lists Treasury approved surety companies and their underwriting limitations.

(f) The bond signed by an agent must be accompanied by a certified copy of such agent's authority to act.

(g) A bond required under this Article must clearly and prominently display on the bond or on an attachment to the bond: (1) the name, mailing address, physical address, and telephone number, including the area code, of the surety company to which any notice of claim should be sent; or (2) the toll-free telephone number maintained by the Texas Department of Insurance under Subchapter B, Chapter 521, Insurance Code, and a statement that the address of the surety company to which any notice of claim should be sent may be obtained from the Texas Department of Insurance by calling the toll-free telephone number.

ARTICLE 8 - LIABILITY

(a) Contractor shall be solely and completely responsible for providing and maintaining safe conditions at any work site.

(b) In addition, the Contractor agrees to keep, save, and hold PCCD harmless from any and all actions, liabilities, damages, judgments, costs and expenses including reasonable attorney's fees, in case an action is filed or does in any way accrue against PCCD, its officials, officers, and employees in consequence of this contract for any negligent act, or omission of the Contractor in the performance of the work under this contract, or that may result from the carelessness or lack of skill of the Contractor or the Contractor's agents, subcontractor, assigns or employees. In the event a judgment is recovered against PCCD for any such liability, costs or expenses, such judgment shall be conclusive against the Contractor. The Contractor is similarly responsible for reimbursement to the PCCD whenever such claims and actions reach voluntary settlements rather than judgments. The Contractor will pay subsequent full contribution to the PCCD.



(c) It is specifically understood and agreed by the Contractor that such indemnity is indemnity by the provider to indemnify and protect PCCD from liability, claims, suits, losses, damages or causes of action caused by or resulting from an act of negligence, intentional tort, intellectual property infringement, or failure to pay a subcontractor or supplier committed by the Contractor, the Contractor's agent, consultant under contract, or any other entity over which the Contractor exercises control. PCCD agrees to give Contractor prompt notice of any claim, control of the defense or settlement of that claim and reasonable assistance and information related to the claim.

ARTICLE 9 – INDEPENDENT CONTRACTOR

The Contractor covenants and agrees that Contractor is an independent contractor and not an officer, agent, servant or employee of PCCD. The Contractor hereby acknowledges that it shall have exclusive control of and exclusive right to control the details of the Work, performed hereunder, and all persons performing same, and shall be liable for the acts and omissions of its officers, agents, employees, and subcontractors.

ARTICLE 10 – DISCLOSURE

(a) By signature of this Contract, the Contractor acknowledges to PCCD that the Contractor has made full disclosure in writing of any existing conflicts of interest or potential conflicts of interest, including personal financial interests, direct or indirect.

(b) The Contractor further agrees that Contractor will make disclosure in writing of any conflicts of interest, which develop subsequent to the signing of this Contract and prior to final payment under the Contract.

ARTICLE 11 – SEVERABILITY

The provisions of this Contract shall be interpreted when possible to sustain their legality and enforceability as a whole. In the event any provision of this Contract shall be held invalid, illegal, or unenforceable by a court of competent jurisdiction, in whole or in part, neither the validity of the remaining part of such provision, nor the validity of any other provisions of this Contract, shall be in any way affected thereby. The unenforceability of any provision of this Contract in a specific situation shall not affect the enforceability of that provision in any other situation.

ARTICLE 12 – ENTIRE AGREEMENT

This Contract sets forth the entire agreement of the PCCD and Contractor with respect to the accomplishment of the Work and the payment of the Contract price therefore, and there are no other understandings or agreements, oral or written, between PCCD and Contractor with respect to the work and the compensation therefore, nor was the making and execution of this Contract induced by any representation, statement, warranty, agreement, or action other than those expressed or explicitly referenced herein.

ARTICLE 13 – HEADINGS

The headings of this Contract are for the convenience of reference only and shall not affect in any manner any of the terms and conditions hereof.

ARTICLE 14 – VENUE

The parties to this Contract agree and covenant that this Contract will be enforceable in Caldwell County, Texas; and that if legal action is necessary to enforce this Contract, exclusive venue will lie in Caldwell County, Texas.



IV – PREVAILING WAGE RATES

[Per PART III – Supplemental Conditions, Article 6 – Wages / Benefits]

Heavy & Highway Construction (Hays County, Texas)

Occupation	Rate	Occupation	Rate
Cement Mason/Concrete Finisher (Paving and Structures)	\$12.56	POWER EQUIPMENT OPERATOR	
		Front End Loader, 3 CY or less	\$13.04
Electrician	26.35	Front End Loader, over 3 CY	13.21
Form Builder/Setter (Paving & Curb)	12.94	Loader / Backhoe	14.12
Form Builder/Setter (Structures)	12.87	Mechanic	17.10
Laborer: Asphalt Raker	12.12	Milling Machine	14.18
Laborer: Flagger	9.45	Motor Grader, Fine Grade	18.51
Laborer: Common	10.50	Motor Grader, Rough	14.63
Laborer: Utility	12.27	Pavement Marking Machine	19.17
Laborer: Pipelayer	12.79	Reclaimer / Pulverizer	12.88
Laborer: Work Zone Barricade Servicer	11.85	Roller, Asphalt	12.78
Painter (Structures)	18.34	Roller, Other	10.50
POWER EQUIPMENT OPERATOR		Scraper	12.27
Agricultural Tractor	12.69	Spreader Box	14.04
Asphalt Distributor	15.55	Trenching Machine, Heavy	18.48
Asphalt Paving Machine	14.36	Servicer	14.51
Boom Truck	18.36	STEEL WORKER	
Broom or Sweeper	11.04	Reinforcing	14.00
Concrete Pavement Finishing Machine	15.48	Structural	19.29
Crane, Hydraulic 80 tons or less	18.36	TRAFFIC SIGNAL INSTALLER	
Crane, Lattice Boom 80 tons or less	15.87	Traffic Signal/Light Pole Worker	16.00
Crane, Lattice Boom over 80 tons	19.38	TRUCK DRIVER	
Crawler Tractor	15.67	Lowboy-Float	15.66
Directional Drilling Locator	11.67	Off Road Hauler	11.88
Directional Drilling Operator	17.24	Single Axle	11.79
Excavator 50,000 lbs. or less	12.88	Single or Tandem Axle Dump Truck	11.68
Excavator over 50,000 lbs.	17.71	Tandem Axle Trailer w/Semi Trailer	12.81
Foundation Drill, Truck Mounted	16.93	Welder	15.97

Notes: Welders receive rate prescribed for craft performing operation to which welding is incidental.



PART V – SPECIFICATIONS / MAPS

The project will encompass one flood control structure fence project for the District's flood control structure: Site 7. The specific site and respective designs are included in this Part V.

Fence Construction Specifications

- 4.1 The following site requires fence removal/disposal and replacement: Site #7 approximately three thousand six hundred and thirty-two feet (3,632).
- 4.2 Contractor shall provide reasonable notice to PCCD when various stages of the work require PCCD inspection and approval prior to commencing with the next step in the work.
- 4.3 **Fence Preparation.** All old fence shall be removed, and new fence shall be installed (see Map #2 below). Contractor shall dispose of all removed gates, braces, concrete footings, t-posts, and barbed wire at an off-site location at Contractor's expense and in accordance with any applicable laws and regulations. Approximately thirty-nine (39) steel posts with concrete footings shall be removed from this site. The concrete on the base of each post is approximately 12" to 20" wide and 8"-36" deep. All holes shall be backfilled with sandy loam type material. All areas where new fence is to be installed shall have brush removed prior to new fence being installed. Brush shall be either mulched on site or disposed of off-site in accordance with any applicable laws and regulations. Contractor shall call for underground utility locating service prior to any fence installation.
- 4.4 **Fence Removal.** Approximate length of fence to be removed is 3,632 feet.
- 4.5 **Fence Replacement.** Approximate length of fence to be constructed is 3,632 feet.
- 4.6 **Wire.** Shall consist of five (5) strands of 2-point 15.5-gauge barbed wire with the top wire located 54" from the ground. A spacing of 9-1/2" shall be maintained between strands. Barbed wire shall be tied to pipe posts with galvanized wire. All inline wire splices shall be "Western Union" style or crimped lug designed specifically for fence wire splicing.
- 4.7 **Line Posts.** Shall be 6'6" long T-Posts, minimum weight shall be at least 1.33 lbs/ft, painted and spaced 12'6" apart. Every 8th post shall be an 8' long 2-3/8" outside diameter or greater galvanized schedule 40 pipe driven into the ground to allow the top of the post to be 56" above the ground. All pipe posts shall have tops capped with cement or welded plates.
- 4.8 **Corner and Gate Posts.** Shall be constructed with 2-7/8" outside diameter or greater galvanized Schedule 40 pipe. Posts shall be driven into the ground a minimum of approximately 5' 0" or set in a hole with concrete to a minimum depth of 4'0". In either case, the top of the post shall be 56" above the ground. The brace post shall be located a minimum of 8'0" from the corner post. The horizontal cross bar between the brace and the corner post shall be 2-3/4" diameter pipe and welded in place 8" down from the top of the post. A second brace post (or angle brace post) shall be 2-3/8" diameter and 4' long. It shall be driven 40" into the ground with 8" left above ground. The angling crossbar between the first brace and the second brace shall be welded in place 8" from the top of the first brace post (or level with the horizontal crossbar) to the top of the angle brace post. All pipe posts shall have tops capped with cement or welded plates and all welds painted with galvanized paint.
- 4.9 **Gates.** Shall be six (6) bar, 1-5/8" minimum galvanized tubular type, and sixteen (16) feet long or six (6) bar, 1-5/8" minimum galvanized tubular type, and ten (10) feet long. Gates shall be installed in four (4)



locations. A total number of five (5) gates will be required for these locations. A total number of three (3) sixteen (16) foot gates and two (2) ten (10) foot gates shall be installed. The three (3) sixteen-foot gates are indicated in yellow on Map #1 below and the two (2) ten-foot gates are indicated in pink. The two ten (10) foot gates shall be installed on North Plum Creek Road or the properties Southernmost border.

- 4.10 **Fence Stile.** Shall be designed and built as specified in Stile Detail Design shown below. Two (2) will be required for this site – one shall be installed at the dam’s toe fence line near the riser and the other shall be installed at the dam’s fence line near the plunge basin pipe. The two (2) Stiles are indicated with a purple + sign on Map #1.
- 4.11 The fence construction project is subject to a final inspection and written approval by PCCD staff prior to approval and payment of Contractor’s final invoice.

Types of Corner Designs Needed for Site #7

O = 27/8” Pipe
X = 4’ Angle Brace Post

		<u>Amount Needed</u>
Type A	O—O	0
Type B	O—O \ X	5
Type C	O—O / \ X X	3
Type D	O—O—O \ X	3
Type E	O—O—O / \ X X	9

*see Map #1 below for the location of each of these types of corners & braces.



Stile Detail Design

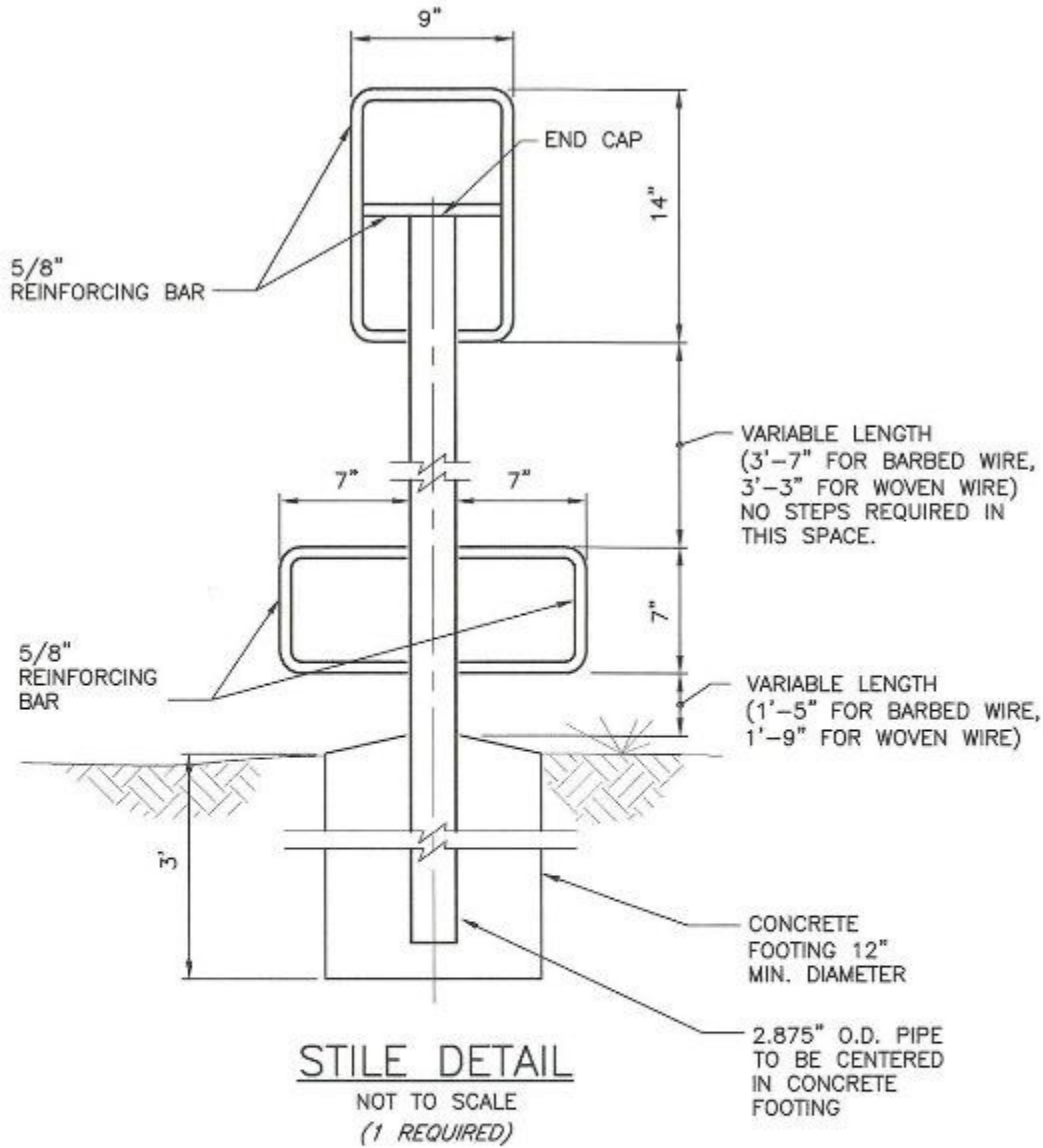

NOTE:

POSITION STILE SO THAT STEPS AND HANDLE ARE PERPENDICULAR TO ALIGNMENT OF FENCE.

ALL BAR BENDS SHOWN SHALL HAVE AN INSIDE RADIUS OF APPROX. $1 \frac{1}{2}$ "

PIPE FOR STILE SHALL BE 2.875" O.D. SCHEDULE 40 STEEL PIPE.

ALL BAR CONNECTIONS SHALL HAVE ALL AROUND FILLET WELD.

ATTACH END CAP TO PIPE WITH ALL AROUND WELD, AND BAR TO END CAP BY WELDING BOTH SIDES.

GALVANIZE STILE AFTER FABRICATION.

THE APPROXIMATE LOCATION OF THE STILE IS SHOWN ON THE DRAWINGS. THE FINAL LOCATION OF THE STILE SHALL BE AS DESIGNATED BY PCCD PERSONNEL DURING FENCE LAYOUT.



Map #1: Site 7 New Fence Construction Project

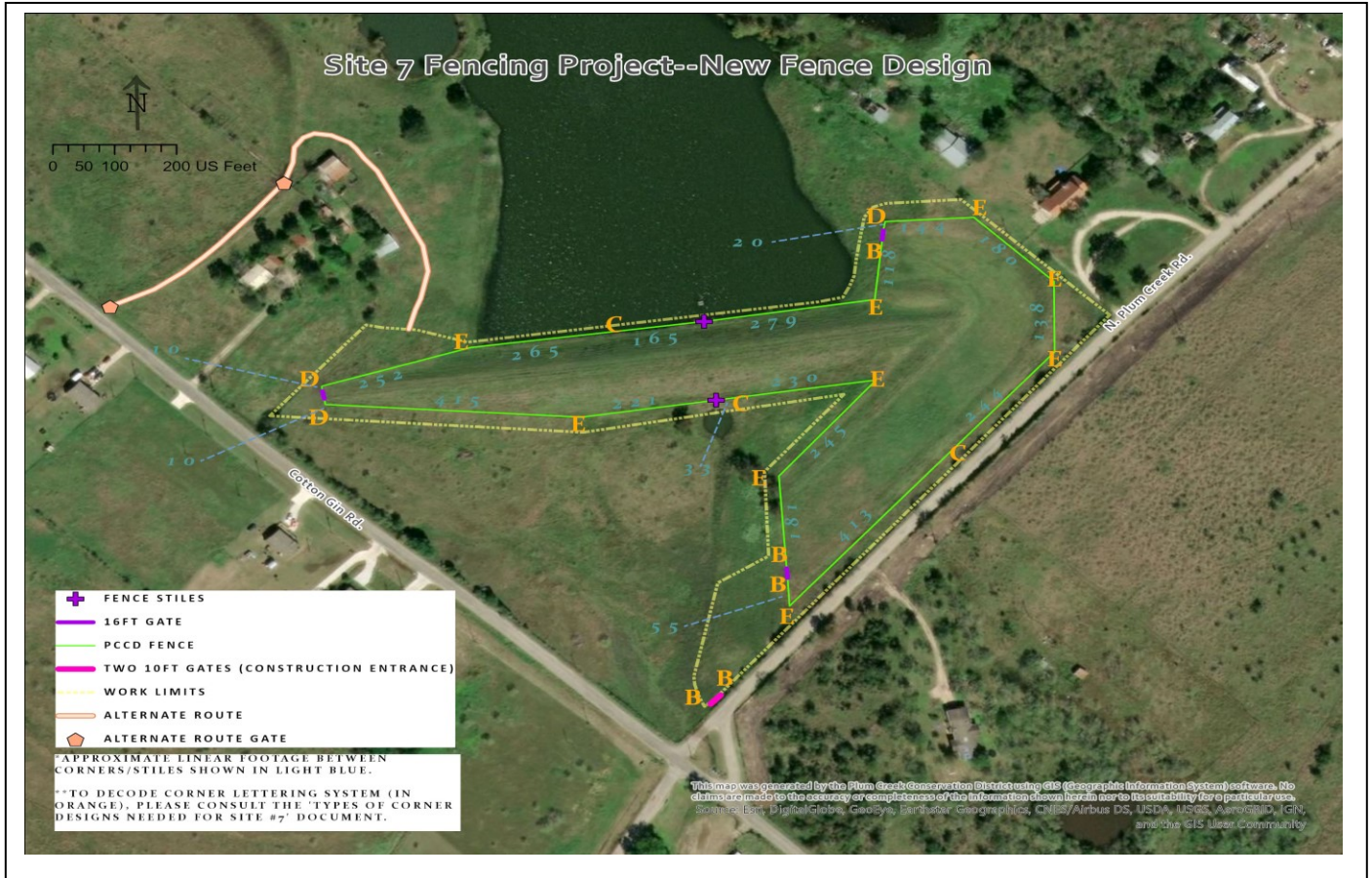



Map #2: Site 7 Old Fence Removal

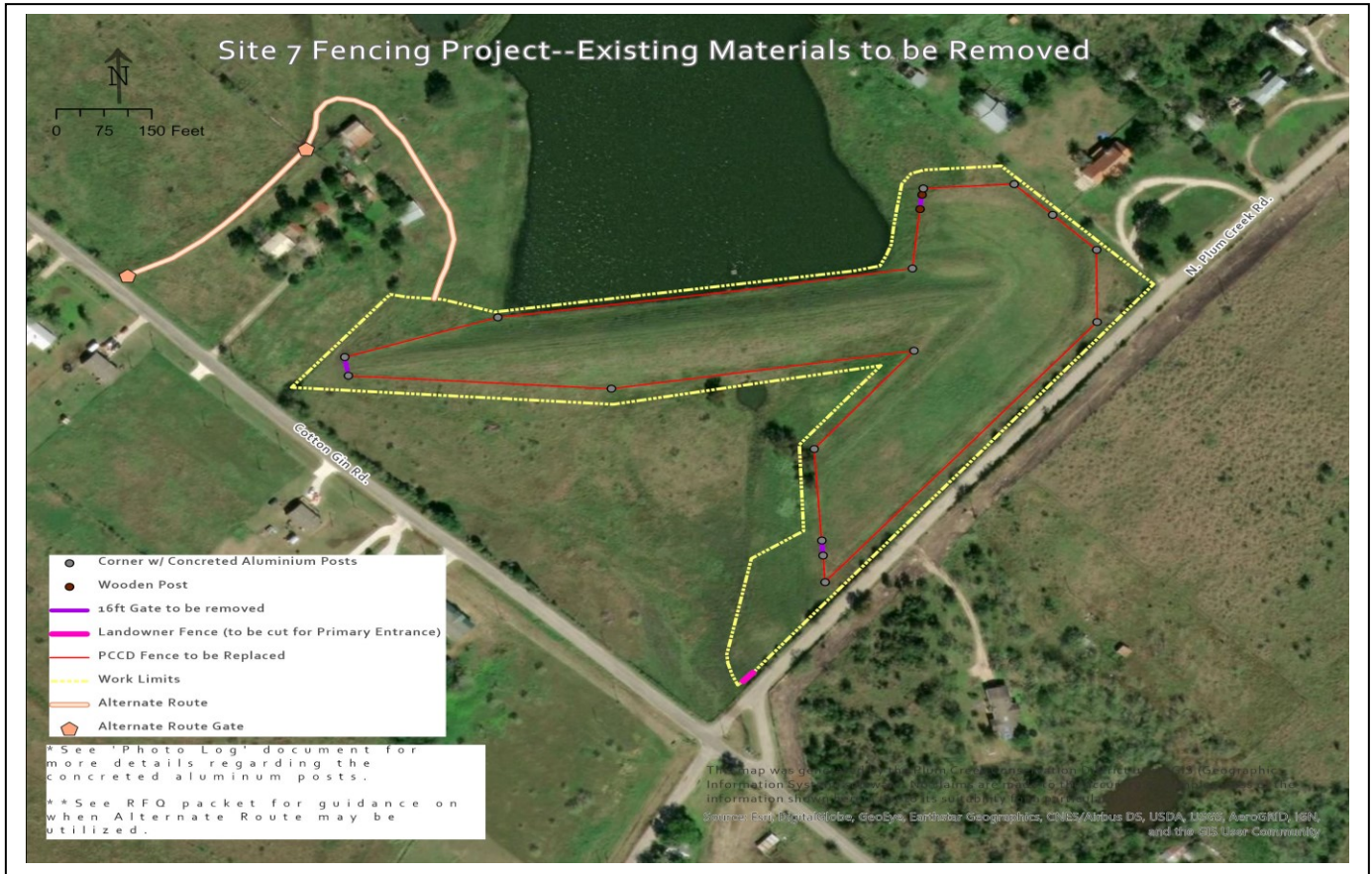



Site 7 Fence Project—Existing Corners Photo Log



Figure 1. A typical existing corner. Note the cable reinforcements.



Figure 2. An example of one of the concreted aluminum posts. PCCD Staff counted 39 such posts on a recent site visit. Most corners have three concretes posts. Concrete diameter was observed to be generally 12-18 inches in diameter. Depth of concrete is unknown.



Figure 3. Note that crossbars are joined with bolt and nut.